

## Technical specifications

### Grade performance

Standard configuration, empty bucket

%	Grade	0.0	2.0	4.0	6.0	8.0	10.0	12.5	14.3	16.0	18.0	20.0	25.0
Ratio	Grade	-	-	-	-	-	1:10	1:8	1:7	-	-	1:5	1:4
km/h	1st gear	4.5	4.4	4.3	4.3	4.2	4.2	4.1	4.1	4.0	4.0	3.9	3.8
	2nd gear	7.4	7.3	7.1	7.0	6.8	6.7	6.5	6.3	6.1	5.4	5.7	5.2
	3rd gear	14.3	13.7	13.1	12.4	11.6	10.8	9.6	8.3	7.1	-	-	-
	4th gear	23.1	21.4	19.1	16.5	12.7	-	-	-	-	-	-	-

3% rolling resistance assumed. Actual performance may vary depending on the application.

### Grade performance

Standard configuration, loaded bucket

%	Grade	0.0	2.0	4.0	6.0	8.0	10.0	12.5	14.3	16.0	18.0	20.0	25.0
Ratio	Grade	-	-	-	-	-	1:10	1:8	1:7	-	-	1:5	1:4
km/h	1st gear	4.4	4.4	4.3	4.2	4.1	4.1	4.0	3.9	3.8	3.8	3.7	3.4
	2nd gear	7.3	7.1	6.9	6.7	6.5	6.3	5.9	5.6	5.4	5.1	4.7	3.5
	3rd gear	14.0	13.2	12.2	11.1	9.8	8.1	-	-	-	-	-	-
	4th gear	22.2	19.3	15.5	-	-	-	-	-	-	-	-	-

3% rolling resistance assumed. Actual performance may vary depending on the application.



## Technical specifications

### Measurements and weights

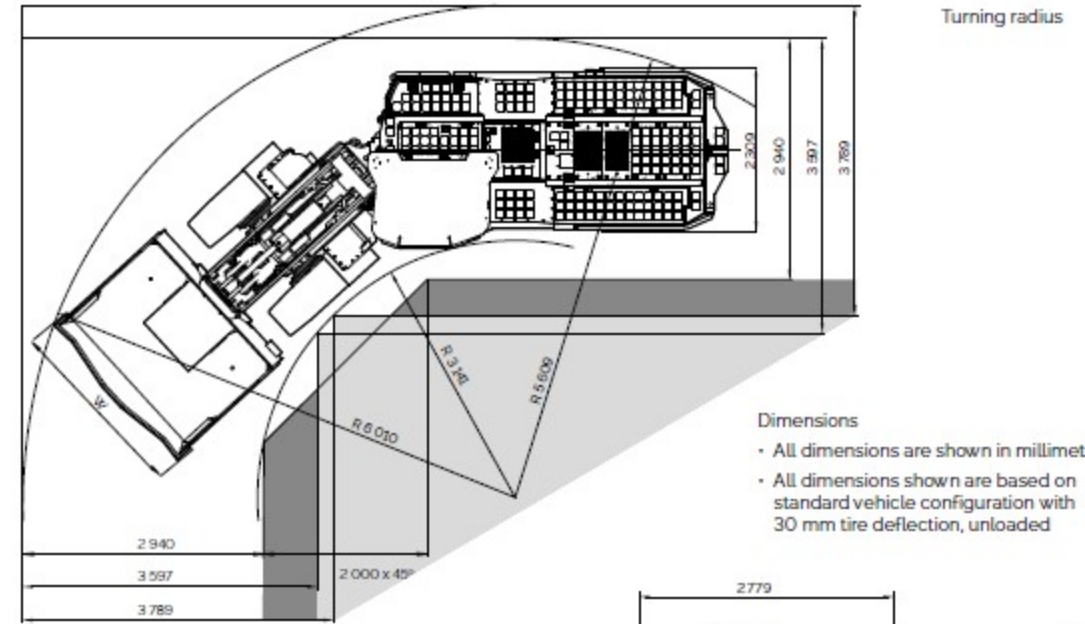

### Side view

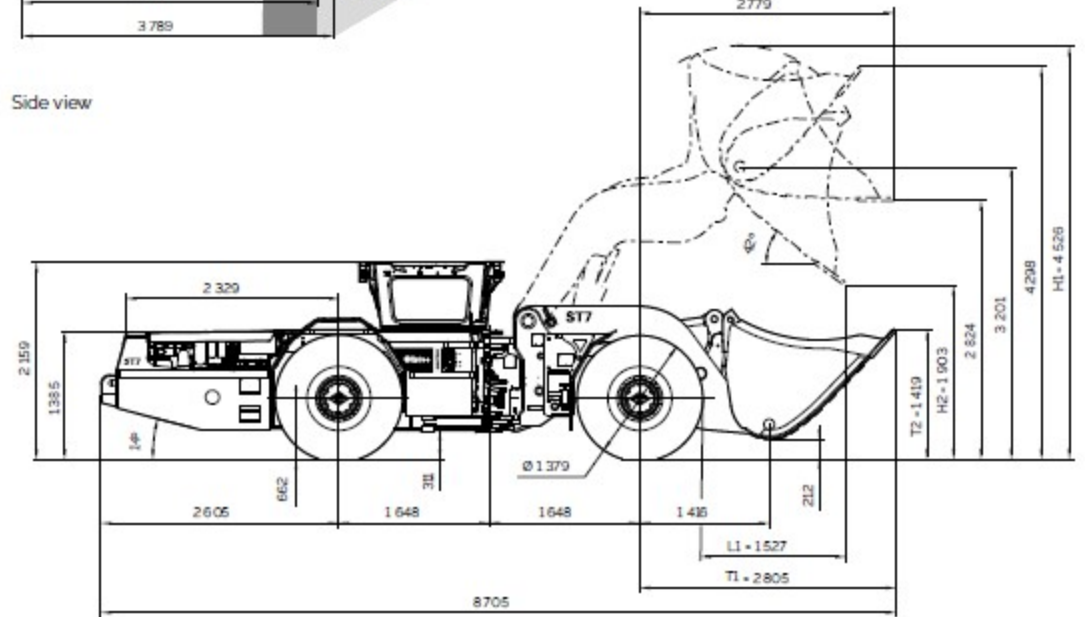

### Bucket data

	Standard							EOD					
	3.8	3.4	3.1	2.8	2.6	2.4	2.3	3.2	2.9	2.7	2.5	2.4	2.2
Volume, nominal heaped (m <sup>3</sup> )	3.8	3.4	3.1	2.8	2.6	2.4	2.3	3.2	2.9	2.7	2.5	2.4	2.2
Maximum material density (t/m <sup>3</sup> )	1.8	2.0	2.2	2.4	2.6	2.8	3.0	1.8	2.0	2.2	2.4	2.6	2.8
Width, bucket (mm)	2 230	2 230	2 230	2 230	2 230	2 230	2 230	2 276	2 276	2 276	2 276	2 276	2 276
Total width (mm)	2 334	2 334	2 334	2 334	2 334	2 334	2 334	2 334	2 334	2 334	2 334	2 334	2 334
Tramming position: axle centreline to bucket tip (mm)	T1 2 970	2 900	2 800	2 770	2 650	2 670	2 600	3 020	2 970	2 920	2 870	2 830	2 780
Tramming position: ground to bucket tip (mm)	T2 1 540	1 450	1 400	1 330	1 200	1 230	1 190	1 650	1 580	1 530	1 480	1 430	1 370
Reach (mm)	L1 1 690	1 594	1 527	1 475	1 334	1 363	1 330	1 757	1 701	1 678	1 621	1 580	1 505
Raised position: max height (mm)	H1 4 760	4 660	4 570	4 540	4 540	4 500	4 490	4 650	4 600	4 530	4 510	4 490	4 490
Raised position: bucket tip height (mm)	H2 1 750	1 850	1 890	1 940	2 050	2 020	2 070	1 700	1 740	1 800	1 840	1 880	1 940